

## AMC609



### KEY FEATURES

- Two 1.8 inch HDDs, up to 320 Gbytes total
- Available with optional Solid State Flash drives
- AMC.1 or AMC.3 options
- IPMI 2.0 compliant
- RoHS compliant
- OS support for:
  - Linux
  - Windows
  - Solaris
  - VxWorks

The AMC609 has two 1.8 inch HDDs in a single-width, half-height (option for mid/full-height) storage module in the Advanced Mezzanine Card (AMC) form factor. The hard disk drives can support data transfer rates of over 570 Mbits/s and provides up to 160 Gbytes of storage capacity per disk. The AMC609 is ideal for adding high-capacity storage and can run as RAID0 (striping across the two drives for increased space and performance) or RAID1 (mirroring the two drives for fault tolerance). It can also run as two independent disks.

The AMC609 allows one of its disks to be removed via the front panel. This eases the removal/replacement of the disk without taking the entire unit out of the system.

The AMC609 is also available with Solid State Flash drives.

VadaTech can modify this product to meet special customer requirements without NRE (minimum order placement is required).

**AdvancedMC™**

# AMC 1.8 Inch Removable Dual Drive Module

## SPECIFICATIONS

Architecture		
Physical	Dimensions	Single-Width, Half-Height (with Mid or Full-Height options)
		Width: 2.89 in. (73.5 mm)
		Depth: 7.11 in. (180.6 mm)
Type	AMC Storage	Two 1.8 inch HDDs
		Optional Solid State Disk Drives (contact sales for capacity and availability)
		5400 RPM, < 15 ms average seek time
		Up to 160 Gbytes capacity per drive
571 Mbits/s transfer rate		
Standards		
AMC Connector	Type	AMC.1 or AMC.3
Module Management	IPMI	IPMI Version 2.0
PCIe	Lanes	x1
Configuration		
Power	AMC609	4W
Environmental	Temperature	Operating Temperature: 0° to 65° C (Air flow requirement is to be greater than 200 LFM)
		Storage Temperature: -40° to +90° C
	Vibration	Operation 2.0G (15-500Hz)
	Shock	Operation 500G/2.0 ms
	Relative Humidity	5 to 95 percent, non-condensing
Front Panel	LEDs	IPMI Management Control Activity
	Mechanical	Hot Swap Ejector Handle
Software Support	Operating Systems	Linux, Windows, Solaris and VxWorks
Other		
MTBF	MII-217-F > 254,000 (without the disk).	
Certifications	Design to meet FCC, CE and UL certifications where applicable	
Standards	VadaTech is certified to both the ISO9001:2000 and AS9100B:2004 standards	
Compliance	RoHS and NEBS	
Warranty	Two (2) years	
Trademarks and Logos	The VadaTech logo is a registered trademark of VadaTech, Inc. Other registered trademarks are the property of their respective owners. AdvancedMC™ and the AdvancedTCA™ logo are trademarks of the PCI Industrial Computers Manufacturers Group. All rights reserved. Specification subject to change without notice.	

# AMC 1.8 Inch Removable Dual Drive Module

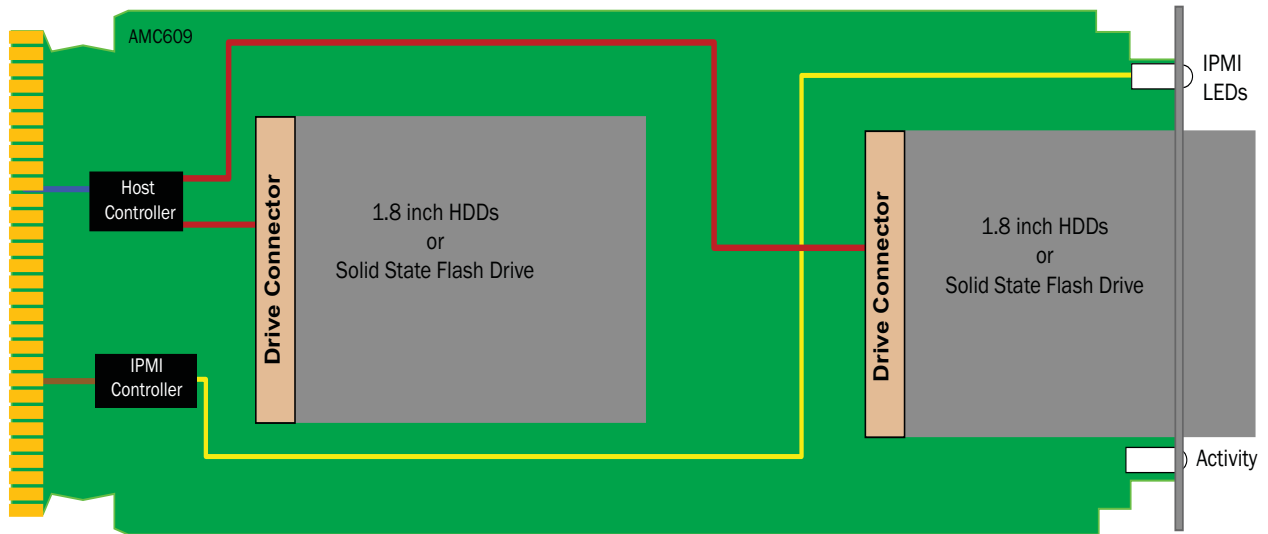

FIGURE 1. AMC609 Functional Block Diagram

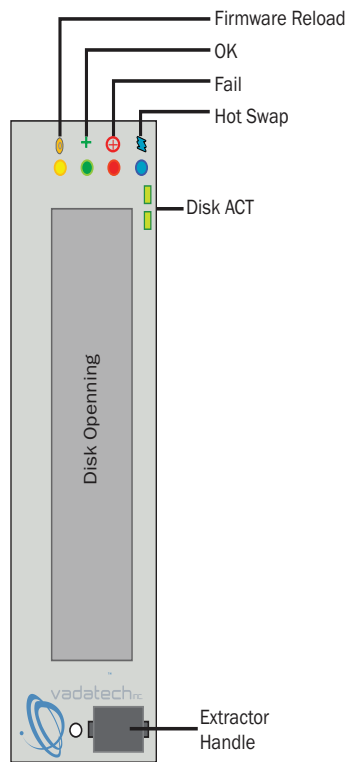

FIGURE 2. AMC609 Front Panel

# AMC 1.8 Inch Removable Dual Drive Module

## ORDERING OPTIONS

### AMC609 - ABC - DE0 - 00J

#### A = Drive Capacity\*

- 1 = 80 Gbytes
- 2 = 160 Gbytes
- 3 = 250 Gbytes
- 4 = 320 Gbytes
- 5 = Reserved
- 6 = Reserved
- 7 = 1.8" Solid State Flash Drive (SSD)  
(Contact Sales for availability)

#### D = Temp

- 1 = Extended  
Temperature Range  
(-20° C to +80° C)
- 2 = Standard  
Temperature Range  
(0° C to +60° C)

#### J = Conformal Coating

- 0 = None
- 1 = Humiseal 1A33 Polyurethane
- 2 = Humiseal 1B31 Acrylic

#### B = Firmware

- 0 = Independent disks
- 1 = RAID0 (striping)
- 2 = RAID1 (mirroring)

#### E = AMC Compliance

- 1 = AMC.1
- 2 = AMC.3

#### C = Front Panel Height

- 1 = Half-Height
- 2 = Mid-Height
- 3 = Full-Height

\*Both disks must be identical



Document No \_\_\_\_\_ Date: June 14 2008 Pass two

